

HP DesignJet T950 Printer Series

Assembly Instructions

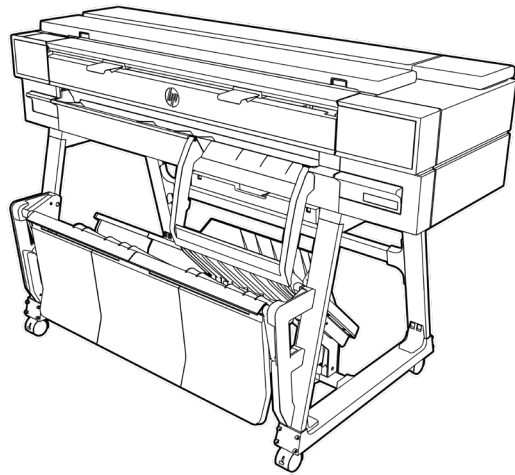

3 people are required to perform certain tasks.

Time required for assembly of the printer is approximately 90 minutes.

Tools required:
 T25 screwdriver (included)
 1 Torx T20 Key (included)

Edition 1
 © Copyright 2023 HP Development Company, L.P.
 Large Format Division
 Camí de Can Graells 1-21
 08174 - Sant Cugat del Valles
 Barcelona - Spain
 All rights reserved
 Printed in XXX



Please read these instructions carefully. These assembly instructions explain how to assemble the printer. Notice that the icons used in this document are also located on the printer packaging. The icons help you locate the parts needed at each stage of the assembly. Because spare screws are supplied, some screws may remain unused after assembly of the printer.

Product working area
 Before you start unpacking, consider where you are going to put the assembled product. You should allow some clear space on all sides of the product box. The recommended clearances are shown in the illustration. To assemble the product you will need at least 3 x 3 m (118 x 118 in) of empty floor space.

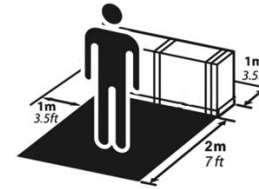

To ensure an accessible operating area for printer use, it is recommended to leave a minimum clear space of 760 mm (30 inches) by 1220 mm (48 inches) with an even level around the sides of the printer. Light reflection (glare) could affect the readability of the control panel, to improve the visibility, select the most suitable theme (dark-light) in the Control Panel.

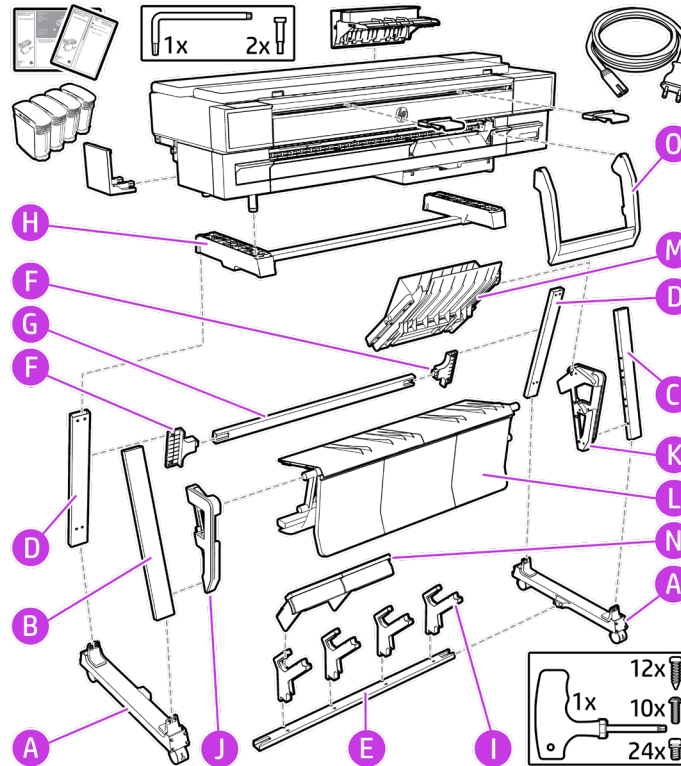
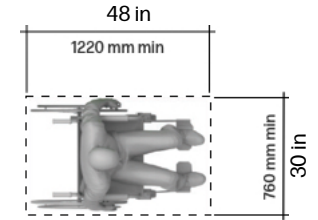

Crate Contents:

- Assembly instructions flyer
- Printer
- HP DesignJet Sheet Organizer

Stand Pieces:

- Left bottom cross-connector (A) + Right bottom cross-connector (A)
- Left front-leg (B)
- Right front-leg (C)
- Right rear-leg (D)
- Left rear-leg (D)
- Bottom cross-tube (E)
- Brackets (F)
- Rear cross-tube (G)
- Top cross beam (H)
- Stacker support Adaptors (I)
- Left Stacker adaptor (J)
- Right Stacker adaptor (K)
- Stacker tray (L)
- Sheet Organizer (M)
- Side blocker (N)
- U-frame (O)

Miscellaneous:

- Screwdriver and screws
- Ink cartridges
- Power cord
- 1 Torx T20 Key
- 2x T20 screws for U-frame
- Cable cover
- Refeed preventers x2 (only T950 MFP)

Be sure to follow the software installation instructions.

Note: LAN cable not included.

Important: Printhead is preinstalled.

Note: Some bags of parts in the box have a label that shows a letter and part number. Please don't remove the bag of each part before you reach to the corresponding assemble step.

Remove the packaging

1



Important: Some bags of parts in the box have a label that shows a letter and part number. Please don't remove the bag of each part before you reach to the corresponding assemble step.

2



<https://www.hp.com/go/DesignJetT950/installation-video>

If this is first time you assemble an HP DesignJet T950 Printer, follow the QR code to watch the installation video before you begin.

3

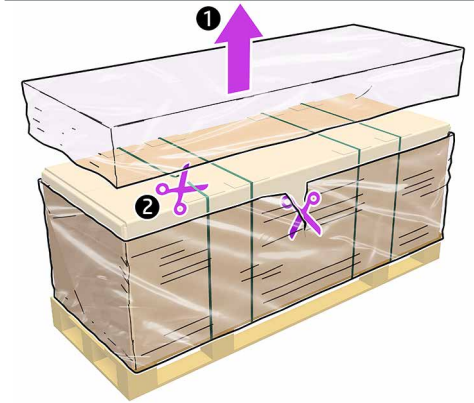

Remove the protective sheet and cut the straps.

4

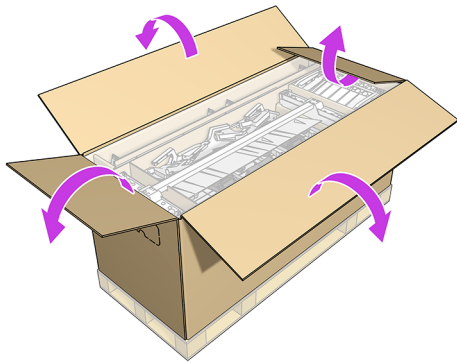

Remove the cover, open the box and remove the inbox contents.

Assemble the stand

5

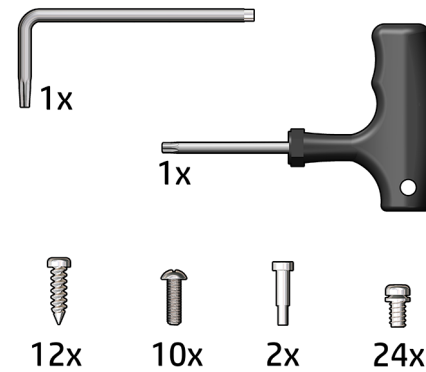

Locate the screwdriver and screws.
Note: There are extra screws.

6

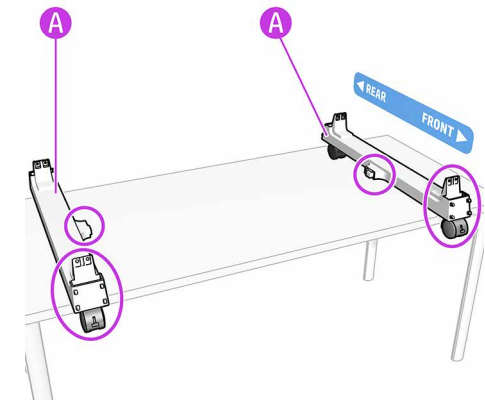

HP recommends completing the assembly on a table. Remove the two bottom cross-connectors (A and A) from the box.
Note: They are symmetrical Position both Bottom Cross Connectors (A and A) on a table with the pins/connectors of both bottom Connectors facing inwards.

Stand Assembly

7

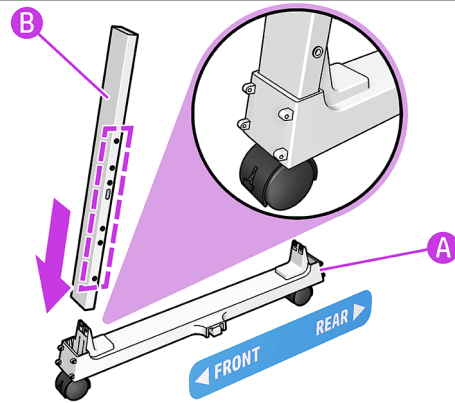

Assemble the Left Side:
 Insert the left front-leg (B) onto the front of the left bottom cross-connector (A).
Note: The holes must face inwards.

8

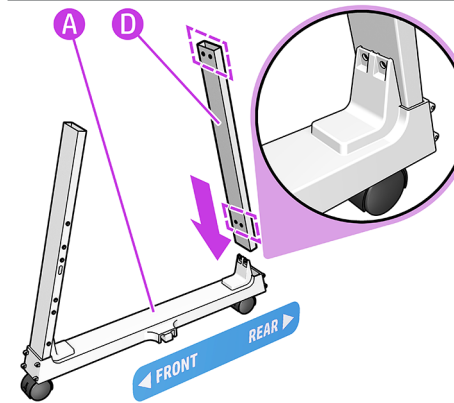

Insert the left rear-leg (D) onto the rear of the left bottom cross-connector (A).
Note: The holes furthest from the end go at the bottom.
Important: Check the holes of the legs and connector align.

9

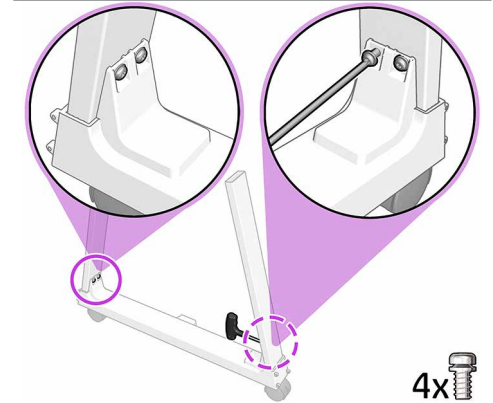

Fix the legs in place with two T25 screws each side.

10

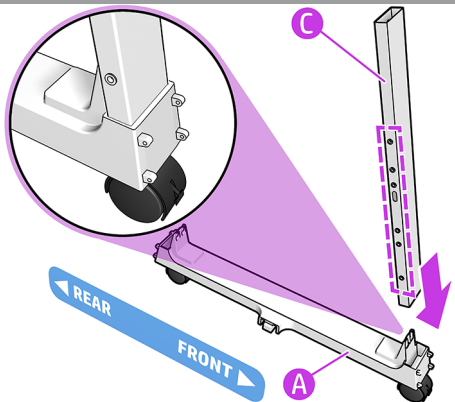

Assemble the Right Side:
 Insert the right front-leg (C) onto the front of the right bottom cross-connector (A).
Note: The holes must face inwards.

11

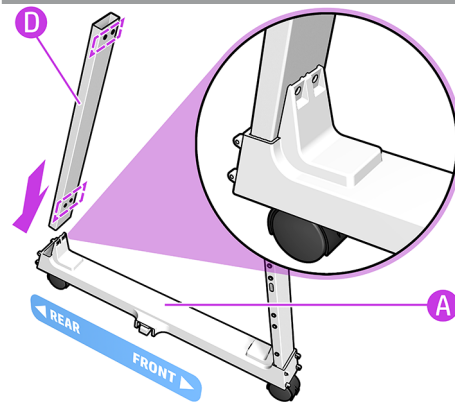

Insert the right rear-leg (D) onto the rear of the right-bottom cross-connector (A).
Note: The holes furthest from the end go at the bottom.
Important: Check the holes of the legs and connector align.

12

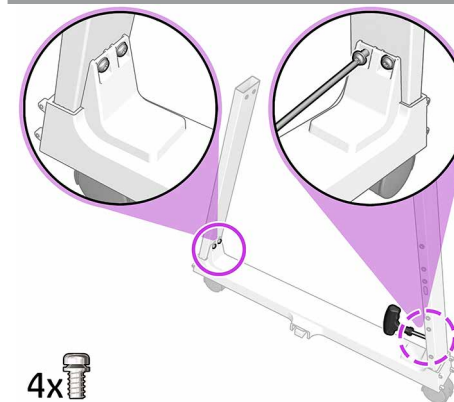

Fix the legs in place with two T25 screws each side.

13

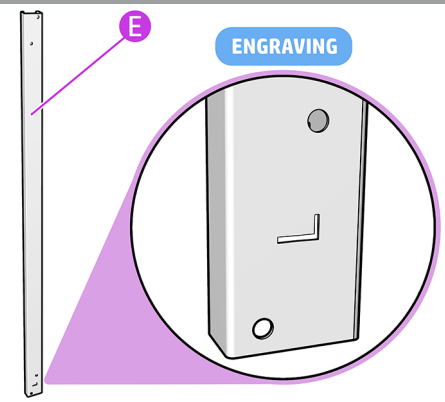

Identify the bottom cross-tube (E).
Note: The holes and the engraved "L" must face towards you.

14

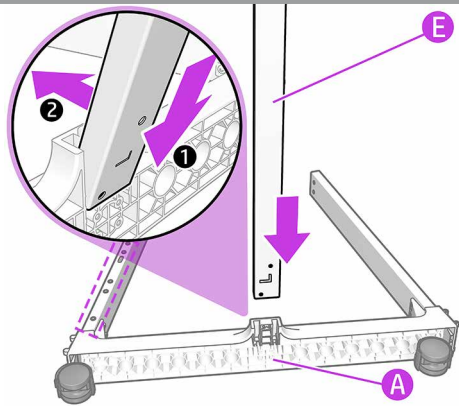

Important: The holes must face inwards. Insert the bottom cross-tube (E) diagonally into the left bottom-connector (A) and push it into place.

15

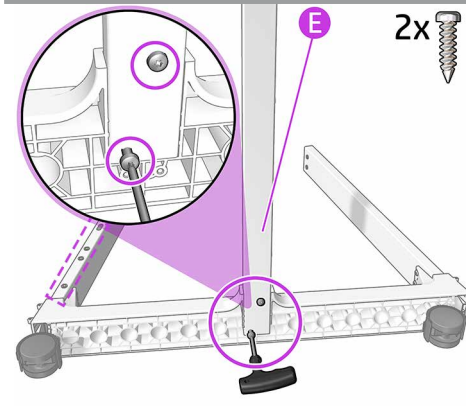

Important: The holes must face inwards. Fix the bottom cross-tube (E) to the left foot using two T25 screws.

16

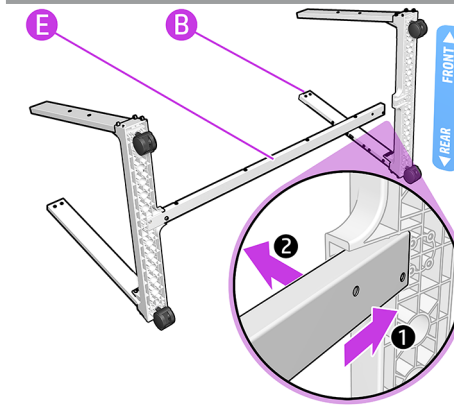

Insert the bottom cross tube (E) diagonally into the right bottom connector (B).

17

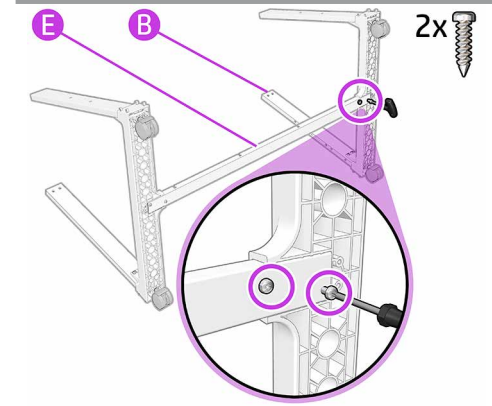

Fix the bottom cross tube (E) to the right bottom connector (B) with two T25 screws.

18

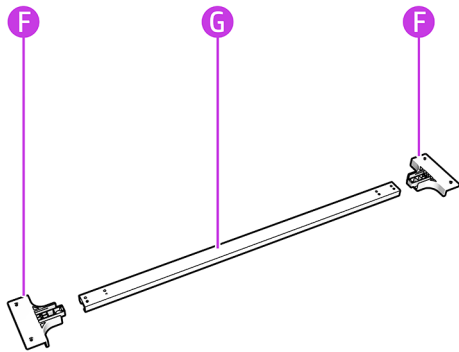

Identify the left and right brackets (F) and the rear cross-tube (G).

19

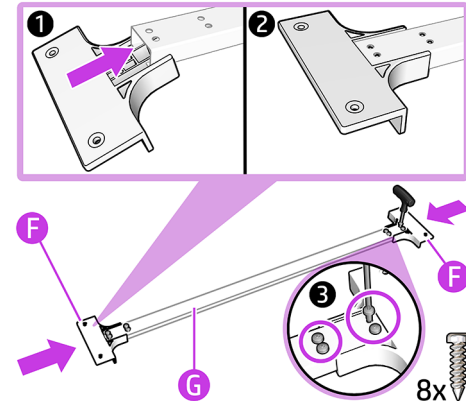

Insert diagonally the left and right brackets (F) into the rear cross-tube (G). Fix them in place using four T25 screws each side.

20

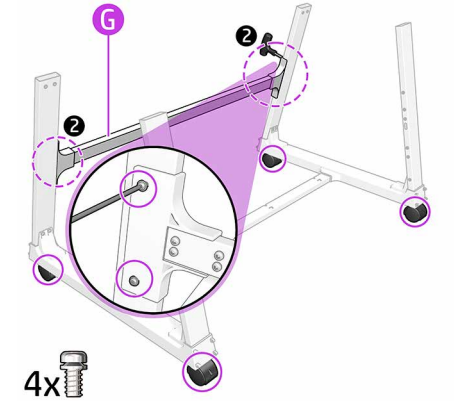

Rotate the assembled stand and place it on the table with the wheels facing down. Fix the rear cross-tube (G) to the rear legs using two T25 screws each side.

21

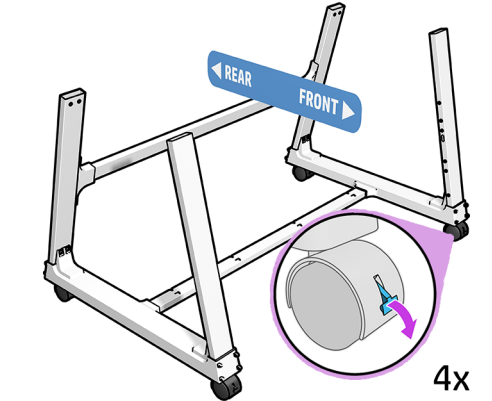

Place the stand upright and check the four wheels are locked.

22

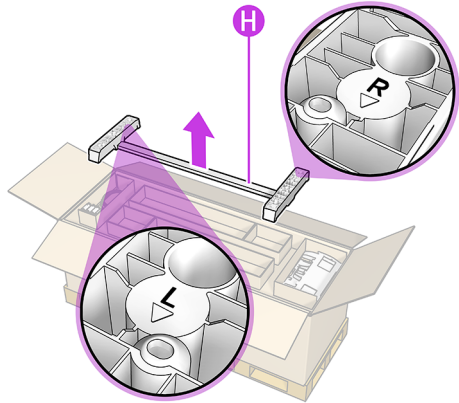

Remove the top cross-beam (H) from the box.

Note: There are letters to indicate the left (L) and right side (R).

23

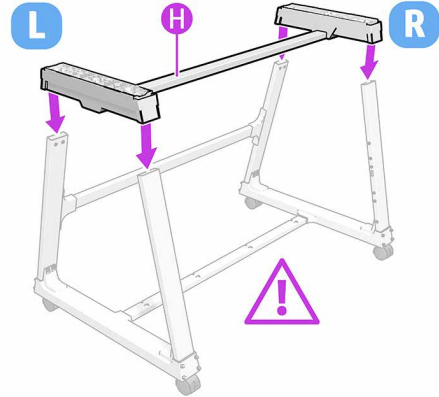

Make sure you identify the front and back of the stand.

Position yourself in front of the stand and carefully connect the top cross-beam (H) to it.
Note: There are marks on the plastic that indicate the left (L) and right side (R).

24

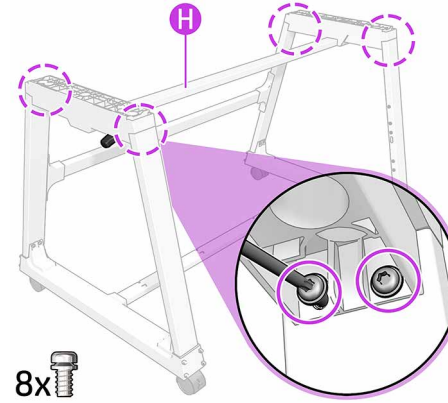

Fix the top cross-beam (H) to the stand using four T25 screws on the left and right side.

25

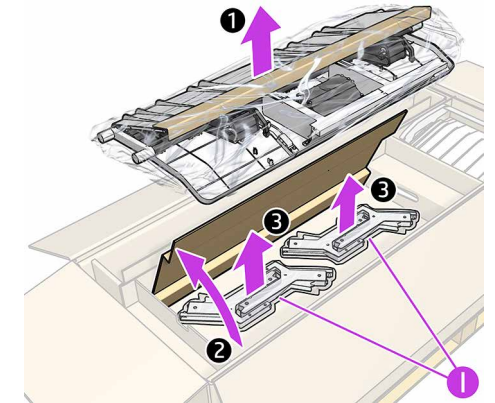

Remove the stacker tray from the box. Open the small compartment located below it. Remove the four Stacker support Adaptors (I) on the top of the stacker.

26

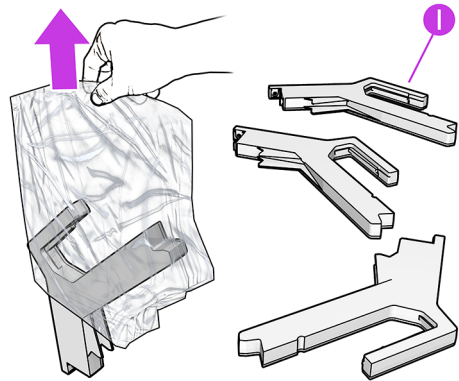

Remove the bag from the four stacker support-adaptors (I).

27

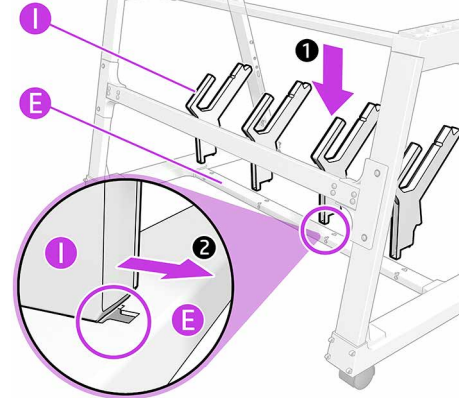

Position the four stacker support-adaptors (I) on the bottom cross-tube (E); insert and rotate, then slide and push to install them one-by-one.

Note: All the stacker support-adaptors are the same.

28

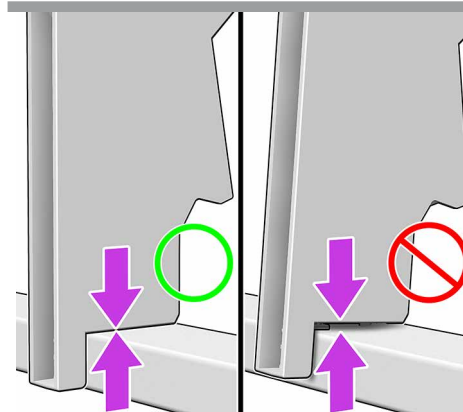

Make sure the four stacker support-adaptors (I) are correctly installed.

29

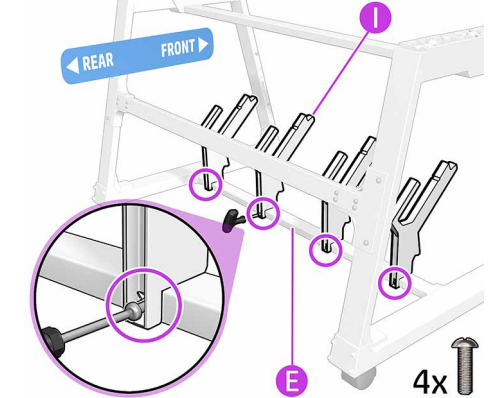

Fix the four stacker support-adaptors (I) onto the bottom cross-tube (E) using four T25 screws.

30

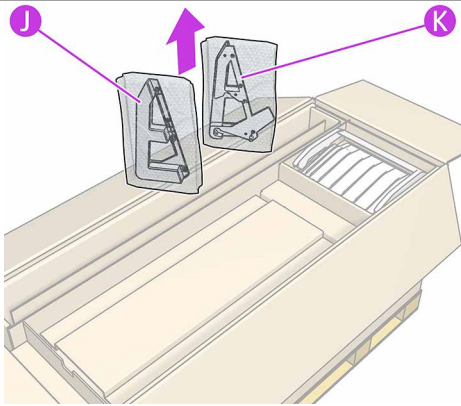

Remove the left stacker-adaptor (J) and right stacker-adaptor (K) from the box.

31

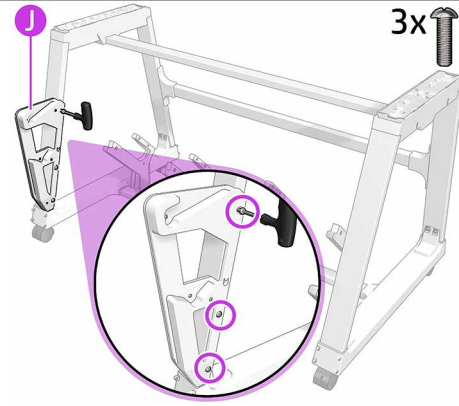

Fix the left stacker-adaptor (J) onto the front left-leg with three T25 screws.

32

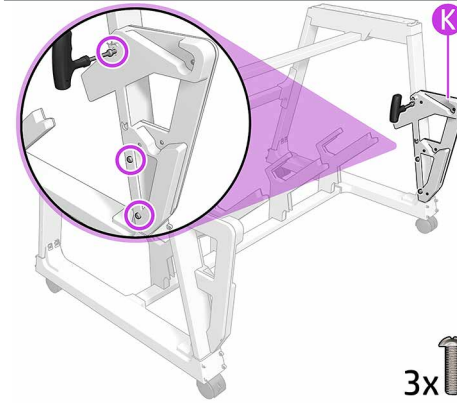

Fix the right stacker-adaptor (K) onto the front right-leg with three T25 screws.

33

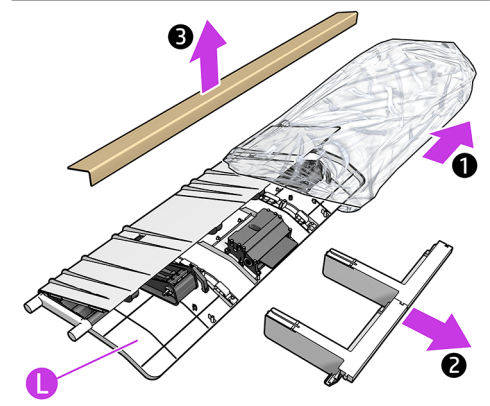

Remove the stacker tray (L) from the bag.

34

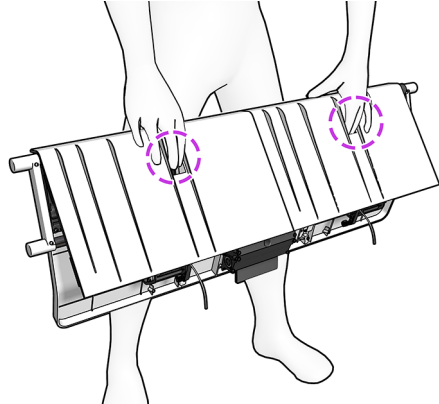

Important: Use the square finger grooves on the stacker to hold it. The black pin should be facing downward.

35

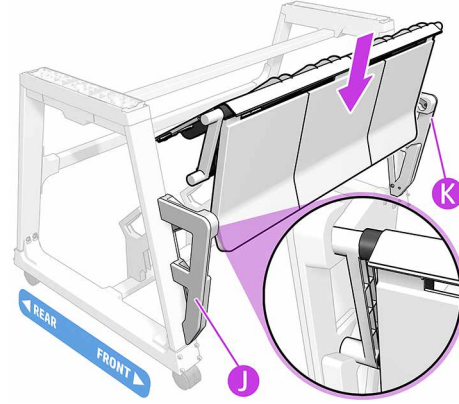

Insert the stacker tray into the right and left stacker-adaptors (K and J).

36

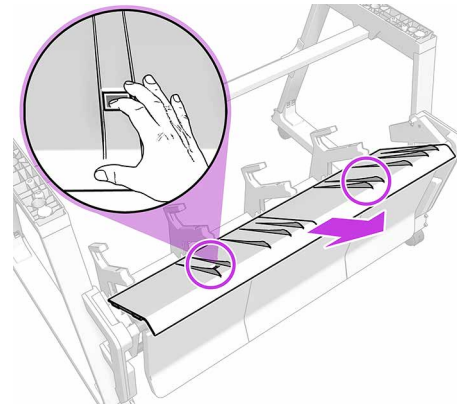

Remove the orange tapes from both sides of the stacker tray. Open the cover and remove the remaining packaging from inside the stacker.

37

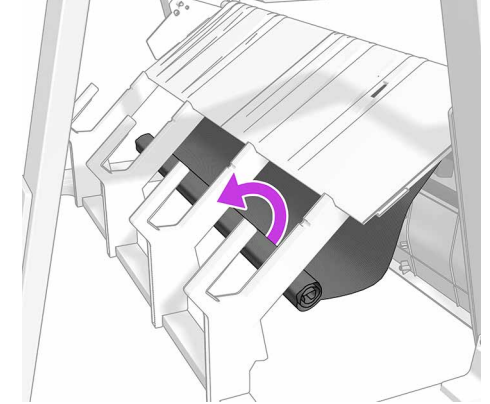

Pull out the basket fabric from inside the stacker tray. Open the Velcro.

38

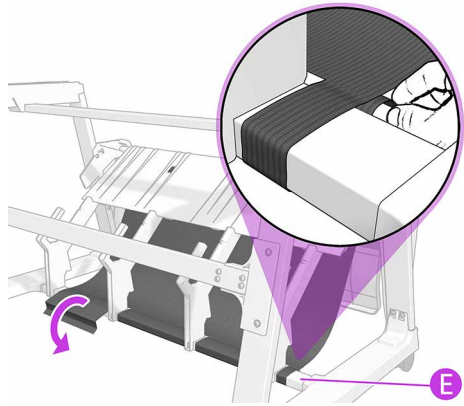

Attach the basket to the bottom cross-tube (E) using the Velcro strap.

39

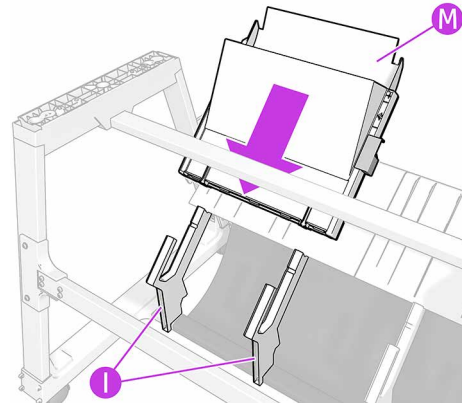

Remove the Sheet Organizer (M) from the bag and slot the two stacker support adaptors (I) at the right.
Note: For easy installation, please use the square finger grooves on the stacker to change to down position before installing the Sheet Organizer (M).

40

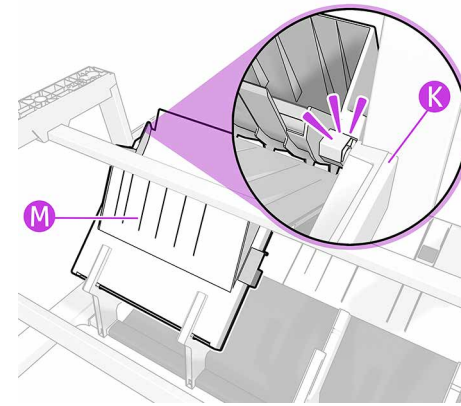

Important: Make sure that the sheet organizer (M) also fits onto the stacker adaptor pin as shown (K). **Remove the packaging from inside of the sheet organizer (M).**
Note: For more information about A3/A4 paper positions, refer to the User Guide.

41

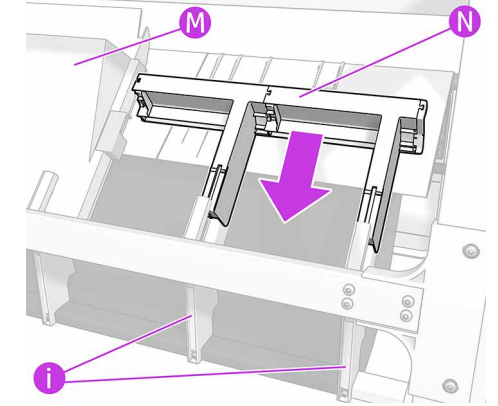

Pull down the stacker tray and slot the side blocker (N) into the unused stacker support-adaptors (I) at the left. Pull up the sheet organizer (M) until it aligns and fits with the side blocker (N), then remove the orange tape.
Important: Ensure that the side blocker (N) fits with the sheet organizer (M).

42

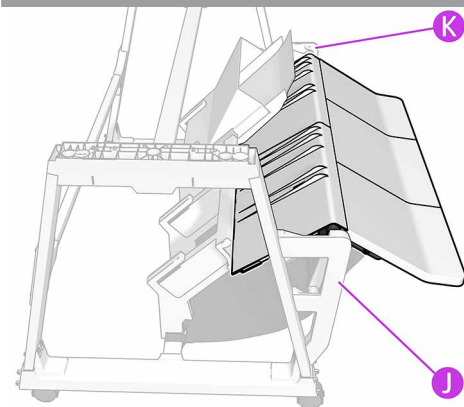

Lift the stacker tray by the slots and insert the bars into the left and right stacker support-adaptors (K and J).

43

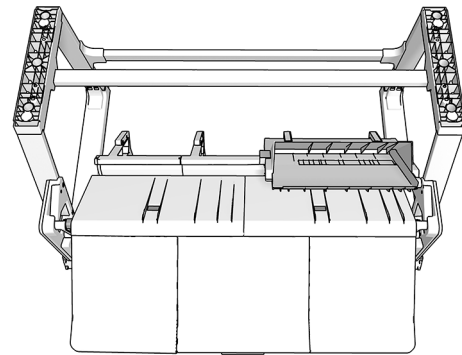

The stacker is now assembled and should look like this.
Note: For more information about stacker positions, refer to the User Guide.

44

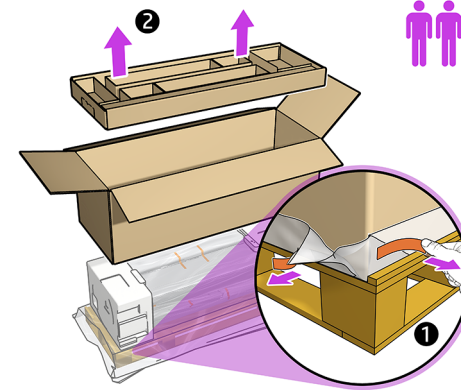

Important: Two people are required.
 Remove the tapes from the film (1), then remove the tray and box (2).

45

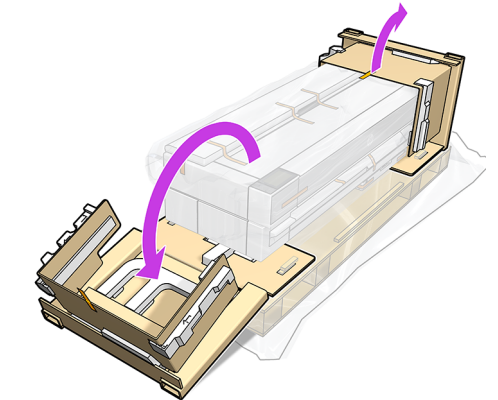

Open the endcaps at both sides of the printer.

46

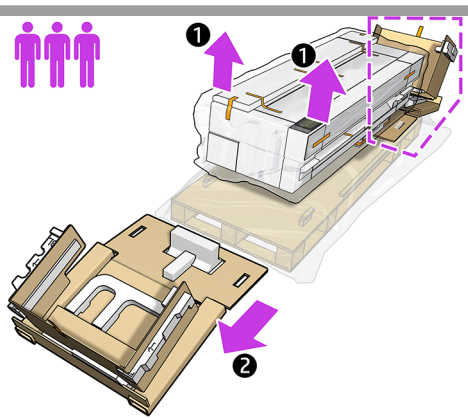

Important: Three people are required.
Using two people; lift the printer from one side (1) while a third person removes the endcap (2).

47

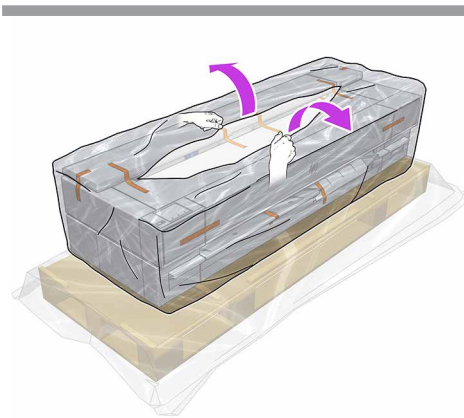

Uncover the printer by tearing open and pulling down the bag.

48

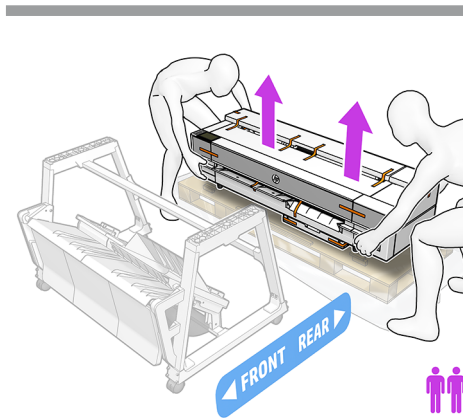

Important: Two people are required.
Move the printer close to the stand, then with two people; lift the printer body by holding the base.

49

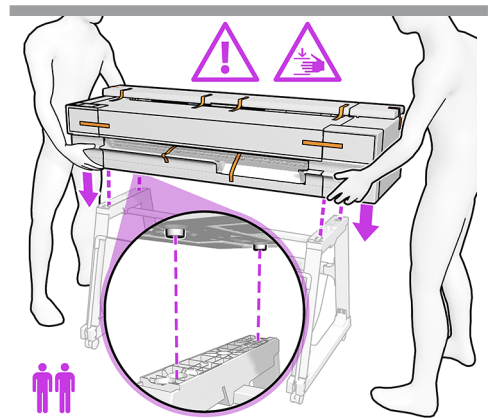

Important: Two people are required.
Caution: Take care not to catch your fingers. Lower the printer into position onto the top cross-beam of the stand.

50

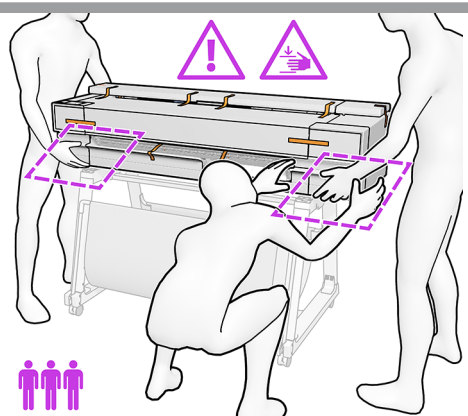

Important: Three people are required.
Caution: Take care not to catch your fingers. Use a third person to adjust the stand position and guide the printer into the correct position.

51

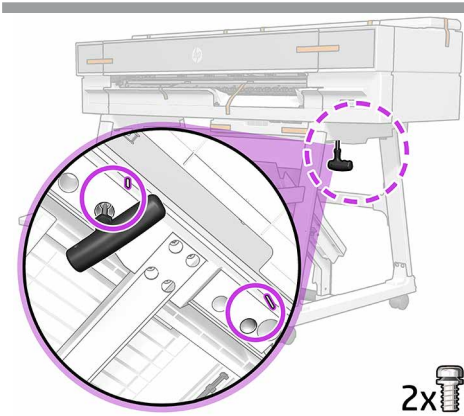

From underneath, fix the right side of the printer to the stand with two T25 screws.
Note: There are marks on the printer that indicate the position of the screws.

52

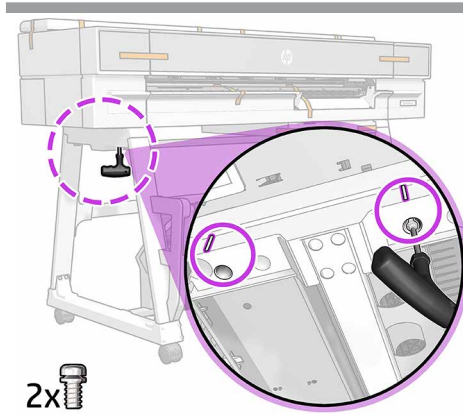

From underneath, fix the left side of the printer to the stand with two T25 screws.
Note: There are marks on the printer that indicate the position of the screws.

53

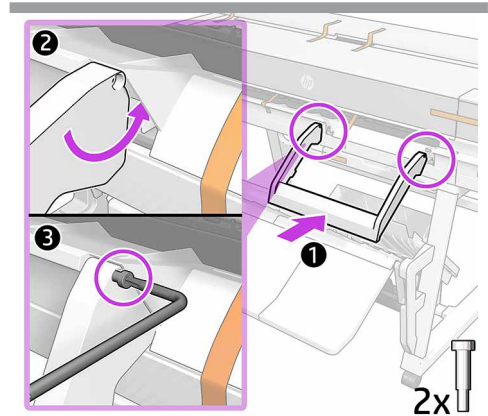

Install the U-frame (O) onto the front of the printer and fix it in place using two T20 screws.



Step only needed for HP DesignJet T950 MFP printers

54

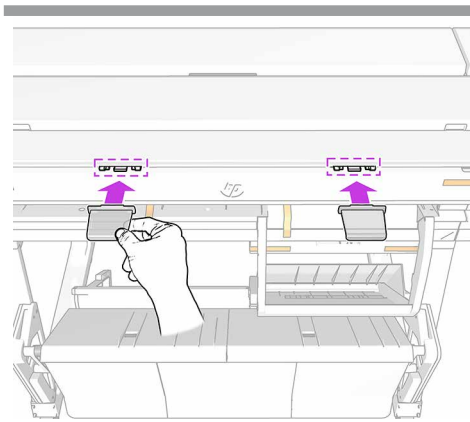

Only for HP DesignJet T950 MFP printers:
Locate the two refeed preventer mounts on the scanner input platen.

55

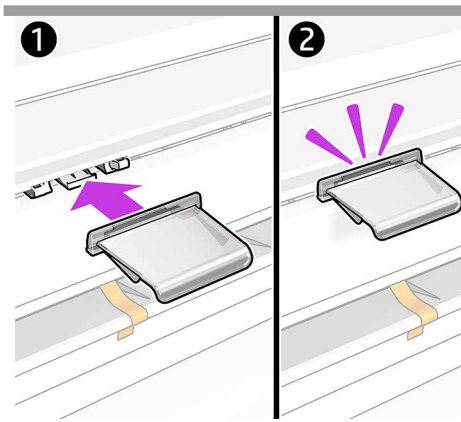

Only for HP DesignJet T950 MFP printers:
Clip the two refeed preventers into position on the mounts.

Remove the Packaging

56

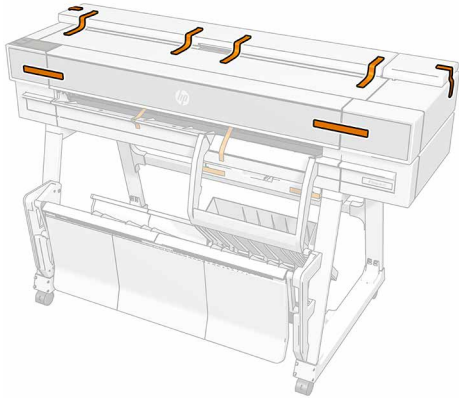

Remove the orange tapes from the top and rear of the printer.

57

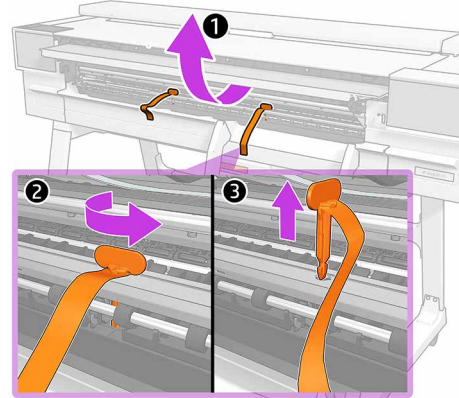

Open the main door. Carefully, rotate and remove the two pins from inside of the printer.

58

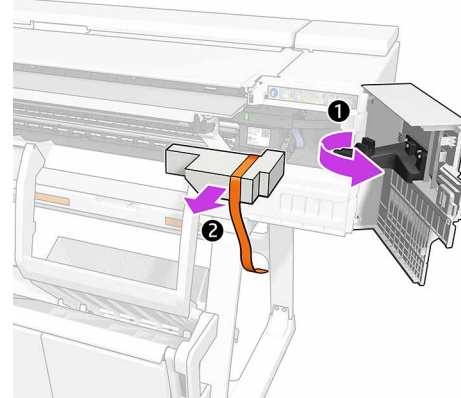

Open the printhead carriage door, remove the foam and close back.

59

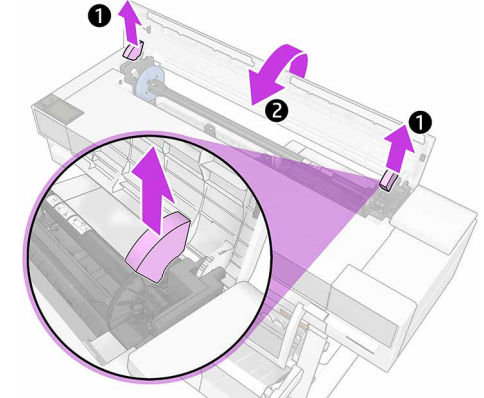

Remove the retainers and cardboard. Close the roll cover.

60

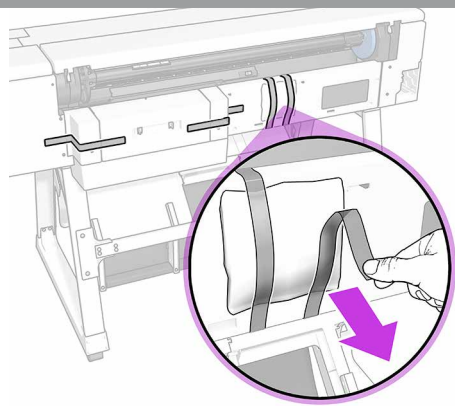

Remove the tapes and dessicant bag.

61

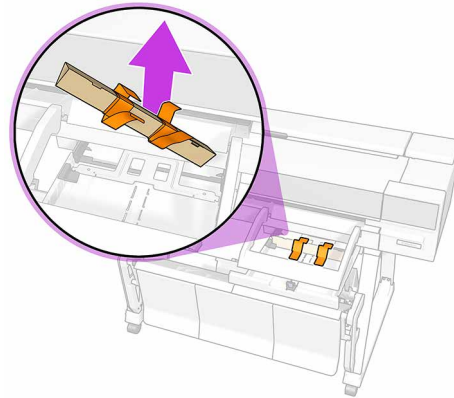

Open the tray and remove the packaging.

62

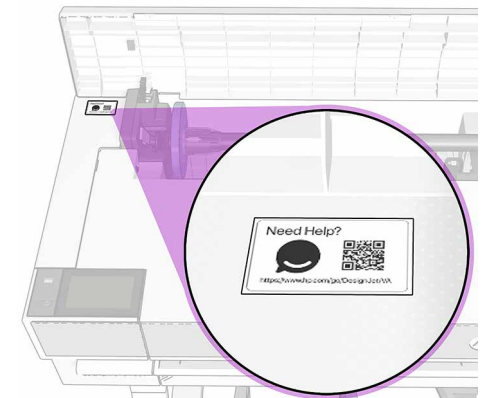
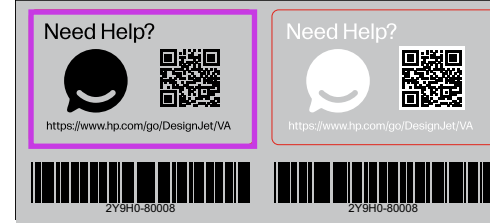

Remove the HP Virtual Assistant label from its bag.

NOTE: You will find both black and white labels.

HP recommends to use the black label for these printer series. Attach it to the printer in a place where it can be easily seen.

HP's Virtual Assistant is always there to troubleshoot issues at any time of the day or night.

Set up the printer

63

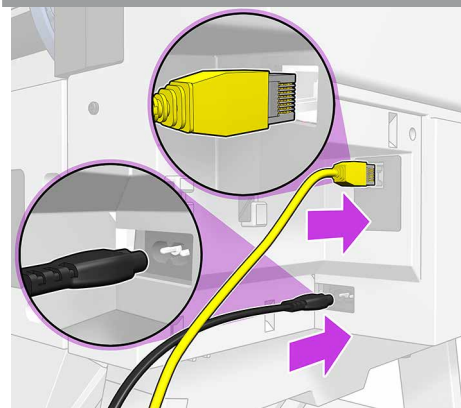

Connect the power cable. Connect a LAN cable (not included).

Note: If you prefer to connect via Wi-Fi, no need to connect the LAN cable. please follow the instructions on the control panel.

64

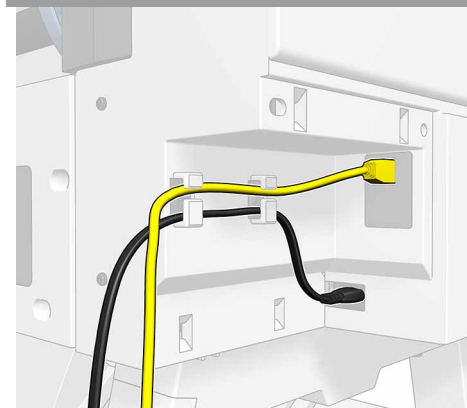

Route the Ethernet cable and power cable though the cable clips.

65

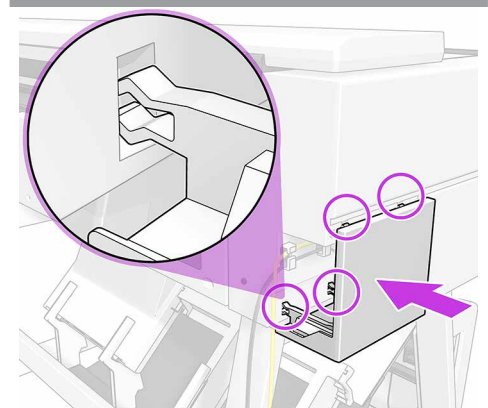

Install the cable cover.

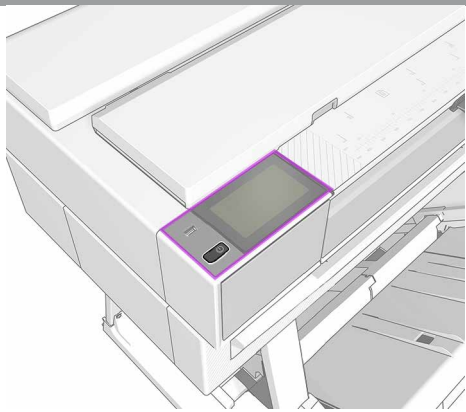

Note: Make sure all the covers are closed before power on the printer. Once all the cables are connected, check that the printer is on. The control panel will now guide you through setup.



<https://www.hp.com/go/T950/drivers>
<https://www.hp.com/go/DesignJetT950MFP/drivers>

Install the product software at :

<https://eoi.hpcloud.hp.com/>

To finish the installation process, it is highly recommended to register the printer by accessing: <https://eoi.hpcloud.hp.com/> and completing the End of Installation Registration survey. Registering the printer has a positive impact on the services provided including unit support and warranty entitlement.

© Copyright 2023 HP Development Company, L.P.
The information contained herein is subject to change without notice. The only warranties for HP products and services are set forth in the express warranty statements accompanying such products and services. Nothing herein should be construed as constituting an additional warranty. HP shall not be liable for technical or editorial errors or omissions contained herein.